



Block Leg Cutters

Block Type 17.5" TCI Cutters

Prime Horizontal is offering durable and high-performance Block Leg Cutters, made by a leading tool manufacturer in the Mining and HDD industries, serving a strong customer base for the last 10 years.

Their product development is aligned with advancements in HDD technology, ensuring reliable performance.

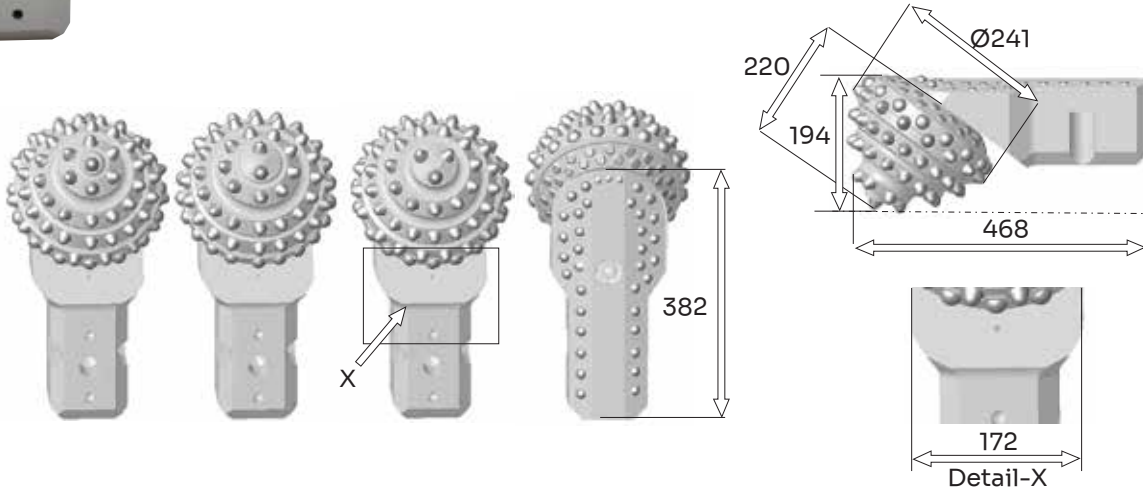

17 1/2" (444.5 mm) TCI Cutter (IADC 635) Features

Product Features

- Spherical inserts on gage row & conical inserts on inner rows
- Full hard facing shirttail protection for medium to hard and moderately abrasive formations
- Double row gage protection with flat inserts
- Block legs available separately for in-house reamer body manufacturer
- In-house/on-site welded block legs assembly

Specifications

Size / Type	17 1/2"	Cutting structure	TCI	Operating Parameters
IADC	635	Rows	01 - Gage / 4/5 - Inner	Cutter (RPM) 30- 70 rpm
Pin Connection	-	Insert/Teeth count	18 - Gage / 51 - Inner	
Bearing	Sealed Roller	Gage inserts/Teeth type	Spherical	Rock UCS 30,000 - 47,500 psi
Circulation type	-	Inner inserts	Conical	
Product weight	95 kg	Shirttail protection	TCI Inserts	
Nozzle	-	Shirttail insert	Spherical	

Note: Operating parameters shown are typical ranges and may vary depending on ground conditions. For recommendations on your specific application, please contact our DownHole representative.